

General Notes:

Products manufactured in accordance with CSA A23.4
 Designed for Boulevard (Off-Road) Use - H-20 Static Loading
 Site Installation, Backfilling & Suitability for Use is the responsibility of others.

ESTIMATED WEIGHT - 135 LBS.

NOTES : NOT FOR USE IN TRAVELLED PORTIONS OF ROADWAY	 DIAMOND PRECAST CONCRETE 7520 Conrad Street Burnaby, B.C. V5A 2H7 Phone : 604 415-9944 Fax : 604 415-9954	DRAWN BY : R.H.	DATE : OCT. 01/13	PRODUCT: METER BOXES	CATALOG NUMBER: MB6613
		APPROVED : LOAD RATING	REV. DATE : REV. NO.	DESCRIPTION: #66 METER BOX GROOVE W/KO 13"H	DWG. NO. SHEET NO. 1 OF 1
MATERIAL SPECIFICATION CONCRETE		SCALE : N.T.S.			

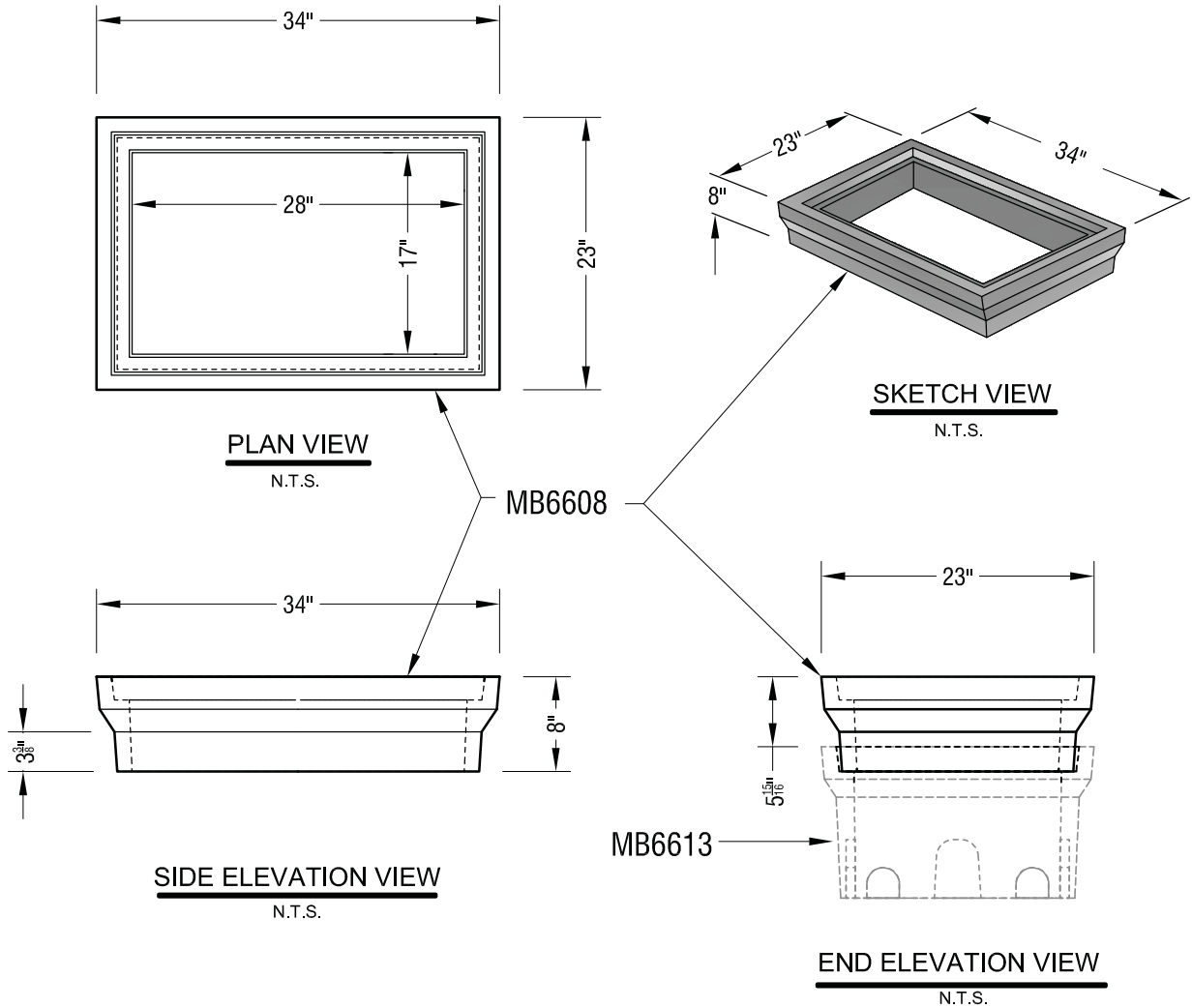

General Notes:

Products manufactured in accordance with CSA A23.4
 Designed for Boulevard (Off-Road) Use - H-20 Static Loading
 Site Installation, Backfilling & Suitability for Use is the responsibility of others.

ESTIMATED WEIGHT - 80 LBS.

NOTES: NOT FOR USE IN TRAVELLED PORTIONS OF ROADWAY	 DIAMOND PRECAST CONCRETE 7520 Conrad Street Burnaby, B.C. V5A 2H7 Phone : 604 415-9944 Fax : 604 415-9954	DRAWN BY : R.H.	DATE : OCT. 01/13	PRODUCT: METER BOXES	CATALOG NUMBER: MB6608
		APPROVED :	LOAD RATING	DESCRIPTION: #66 METER BOX GROOVE W/KO 8"H	DWG. NO.
MATERIAL SPECIFICATION	CONCRETE	REV. DATE :	REV. NO.		SHEET NO. 1 OF 1
		SCALE : N.T.S.			