

TR-200

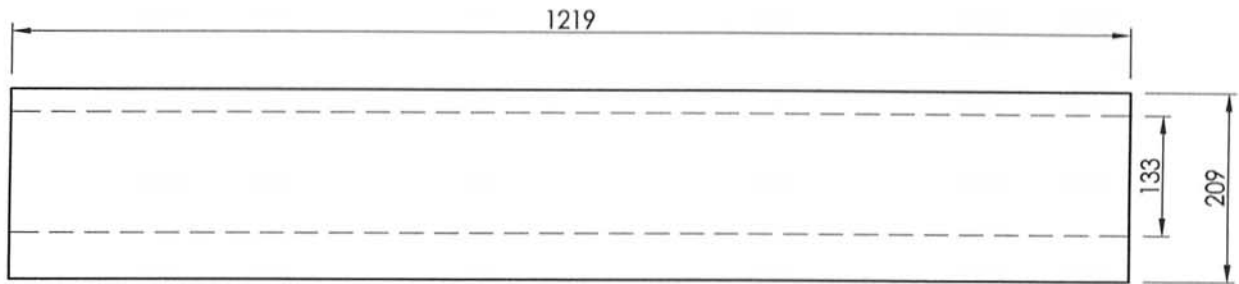

ELEVATION VIEW
SCALE : 1:8

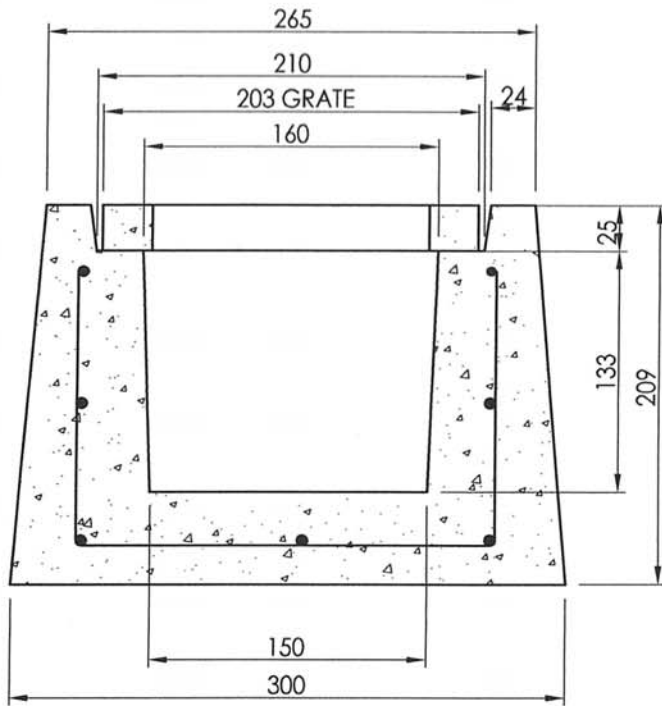

SECTION A-A
SCALE : 1:4

ESTIMATED WEIGHT 95 LBS
TWO PCS OF D824 GRATES NEEDED



PRODUCT:
TRENCH 200

DESCRIPTION:
Driveway Trench 48"L x 8"H x 8"ID #210

Drawn :
AM

Date :
26/11/2014

Catalogue No

TR-200

Approved :

Load Rating:

Dwg. No.

TR-200-1

Rev. No.

Scale :
As Shown

Sheet No.

1 OF 1

7520 Conrad Street Burnaby, B.C. V5A 2H7 Phone : 604-415-5181 Fax : 604-415-5185

This drawing is the property of the Diamond Precast Concrete. All information contained herein is confidential and may not be used in whole or in part without written permission from the owner

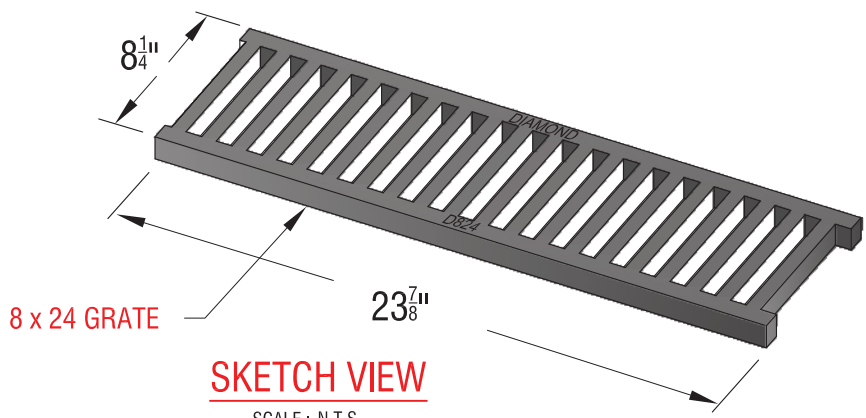

SKETCH VIEW
SCALE : N.T.S.

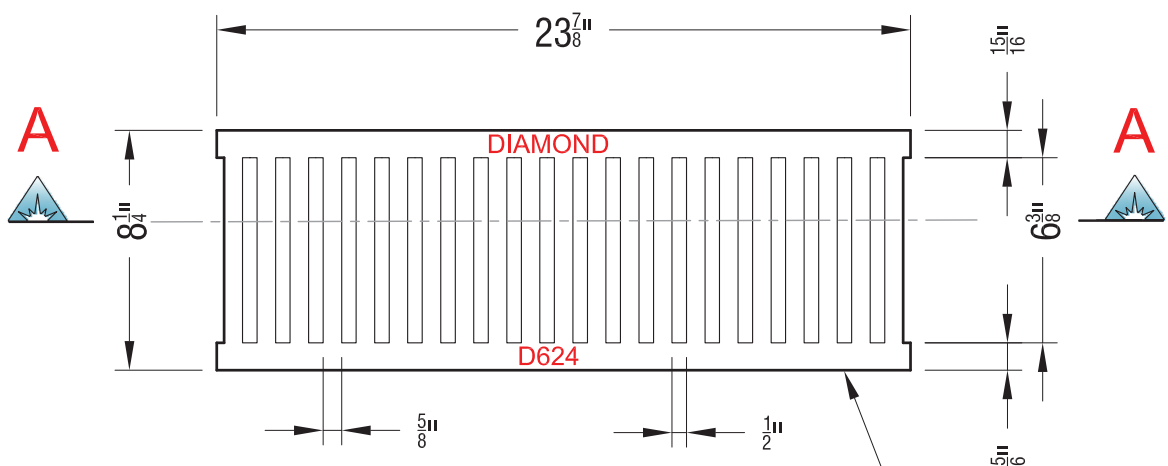

PROFILE VIEW
SCALE : N.T.S.

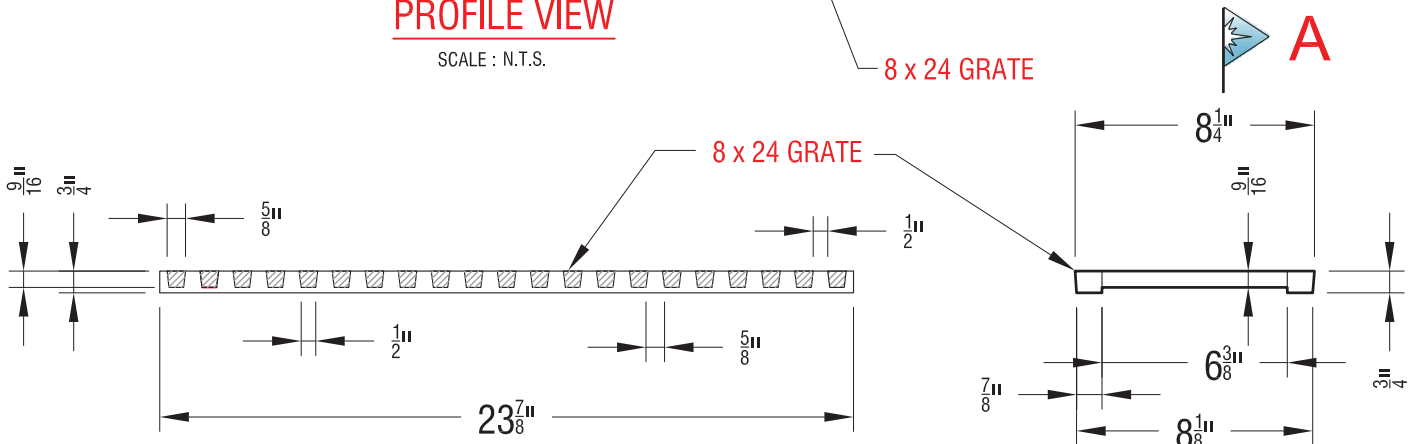

SECTION A-A
SCALE : N.T.S.

END VIEW
SCALE : N.T.S.

ESTIMATED WEIGHT - 19 LBS

NOTES :	 DIAMOND PRECAST CONCRETE 7520 Conrad Street Burnaby, B.C. V5A 2H7 Phone : 604 415-5181 Fax : 604 415-5185	DRAWN BY :	DATE :	PRODUCT:	DIAMOND ITEM NUMBER:	
		R.H.	OCT. 11/13			CASTING
MATERIAL SPECIFICATION: CI-GRADE AS PER ASTM A 48		APPROVED :	LOAD RATING	DESCRIPTION:	DWG. NO.	
		REVISION :	REV. NO.		8 x 24 GRATE FOR DRIVEWAY TRENCHES	DC82412
		SCALE :				SHEET NO. 1 OF 1
		N.T.S.				