

**Specification and General Notes:**

1. Manhole design/manufacture to ASTM C478M & CSA A257.3 Specification.
2. Concrete testing to ASTM C497/CSA 23.1 & 2-09.
3. Min. concrete compressive strength 30 MPa with Max. W/C ratio of 0.5
4. Gasket to ASTM C-443 specification (by others).
5. Concrete cover to be Min.25mm.
6. All dimensions to be millimeter.
7. Welded wire mesh overlap to be 300mm.
8. Manhole design and construction to MMCD manhole specification section 02725.
9. Manufacturing tolerance to be +/- 5mm.
10. Concrete Exposure Class to be A-3
11. Min. Stripping Strength to be 15MPa
12. All Form Finish to be Standard Grade
13. All Unformed Finish to be Steel Trowelled Finish or Wood Float Finish
14. Lifting cable and accessories to meet the strength requirement in lifting detail
15. Hoisting and Rigging system to meet WORK SAFE BC OHS Regulation Guideline Part 14/15



Description:	<b>762ID x 914H Sump/Catch Basin GT</b>	
	30"ID x 36"H Catch Basin 1150 #	
Project:		

Drawn :	Date :	Catalog No. <b>3036CBS</b>
D.N.	11/08/2014	
Approved :	Load Rating:	Dwg. No. <b>30-05</b>
	N/A	
Rev. No.	Scale :	Sheet No. 1 OF 1
	As Shown	

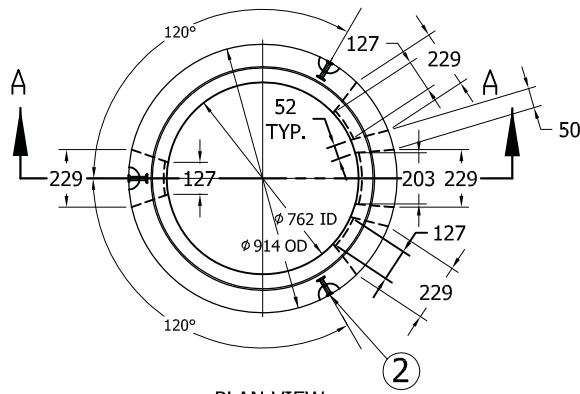

PLAN VIEW  
SCALE 1:30

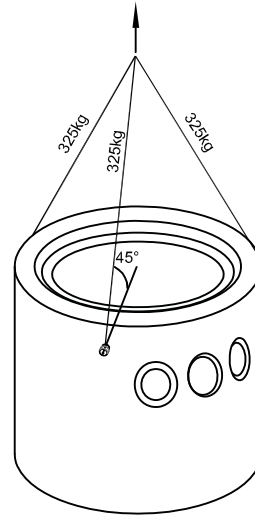

Lifting Detail

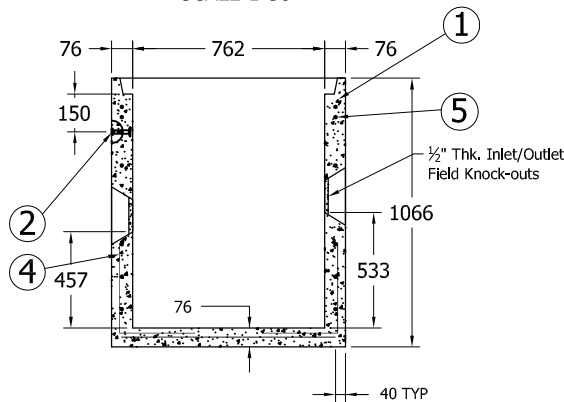

SECTION A-A  
SCALE 1:30

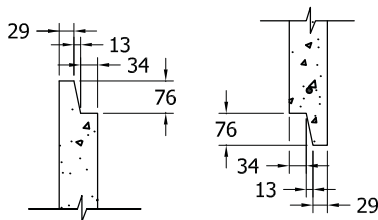

TONGUE & GROOVE DETAIL  
SCALE 1 : 15

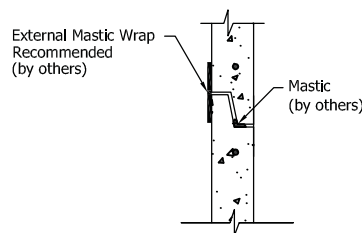

SUGGESTED JOINT DETAIL  
SCALE 1 : 15

**Specification and General Notes:**

1. Manhole design/manufacture to ASTM C478M & CSA A257.3 Specification.
2. Concrete testing to ASTM C497/CSA 23.1 & 2-09.
3. Min. concrete compressive strength 30 MPa with Max. W/C ratio of 0.5
4. Gasket to ASTM C-443 specification (by others).
5. Concrete cover to be Min.25mm.
6. All dimensions to be millimeter.
7. Welded wire mesh overlap to be 300mm.
8. Manhole design and construction to MMCD manhole specification section 02725.
9. Manufacturing tolerance to be +/- 5mm.
10. Concrete Exposure Class to be A-3
11. Min. Stripping Strength to be 15MPa
12. All Form Finish to be Standard Grade
13. All Unformed Finish to be Steel Trowelled Finish or Wood Float Finish
14. Lifting cable and accessories to meet the strength requirement in lifting detail
15. Hoisting and Rigging system to meet WORK SAFE BC OHS Regulation Guideline Part 14/15



Description:  
**762ID x 1067H OIL INTERCEPTOR**

30"ID x 42"H INTERCEPTOR 1280 #

Project:

Drawn :

D.N.

Approved :

Rev. No.

Date :

11/08/2014

Load Rating:

N/A

Scale :

As Shown

Catalog No.

**3042CBOI**

Dwg. No.

**30-08**

Sheet No.

1 OF 1

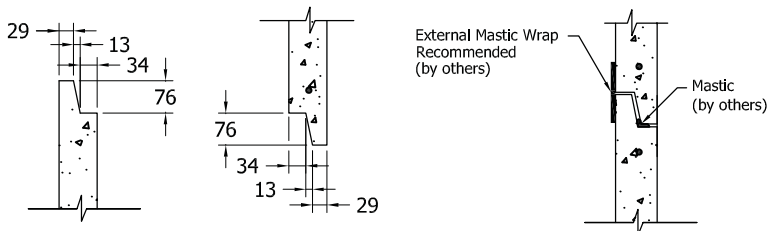
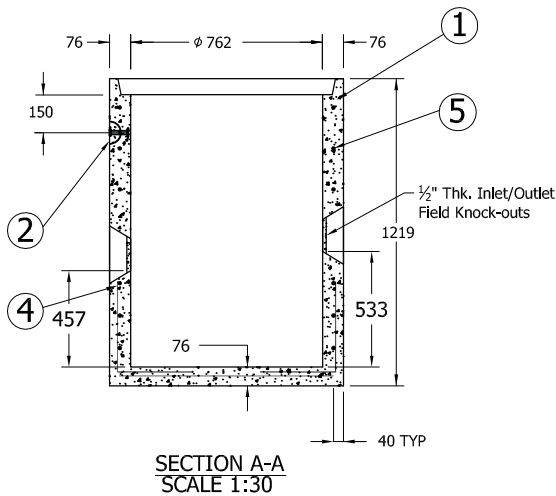
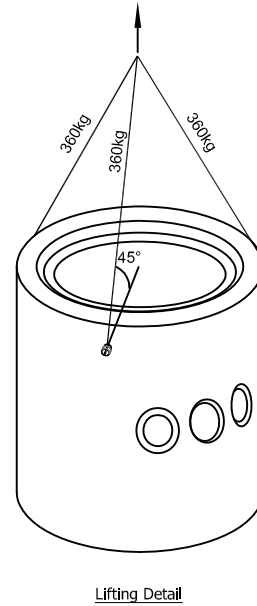
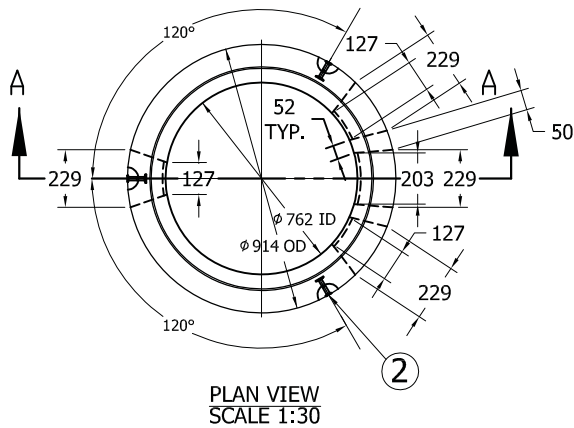

**Specification and General Notes:**

1. Manhole design/manufacture to ASTM C478M & CSA A257.3 Specification.
2. Concrete testing to ASTM C497/CSA 23.1 & 2-09.
3. Min. concrete compressive strength 30 MPa with Max. W/C ratio of 0.5
4. Gasket to ASTM C-443 specification (by others).
5. Concrete cover to be Min.25mm.
6. All dimensions to be millimeter.
7. Welded wire mesh overlap to be 300mm.
8. Manhole design and construction to MMCD manhole specification section 02725.
9. Manufacturing tolerance to be +/- 5mm.
10. Concrete Exposure Class to be A-3
11. Min. Stripping Strength to be 15MPa
12. All Form Finish to be Standard Grade
13. All Unformed Finish to be Steel Trowelled Finish or Wood Float Finish
14. Lifting cable and accessories to meet the strength requirement in lifting detail
15. Hoisting and Rigging system to meet WORK SAFE BC OHS Regulation Guideline Part 14/15



Description:	<b>762ID x 1219H Oil Interceptor</b>	
	30"ID x 48"H Oil Interceptor 1490 #	
Project:		

Drawn :	Date :	Catalog No. <b>3048CBOI</b>
D.N.	11/08/2014	
Approved :	Load Rating:	Dwg. No. <b>30-07</b>
	N/A	
Rev. No.	Scale :	Sheet No. 1 OF 1
	As Shown	