

5436PB

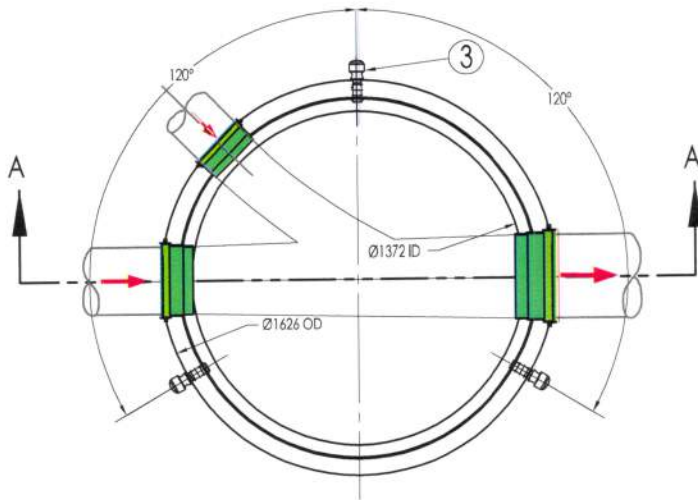

PLAN VIEW
SCALE 1:30

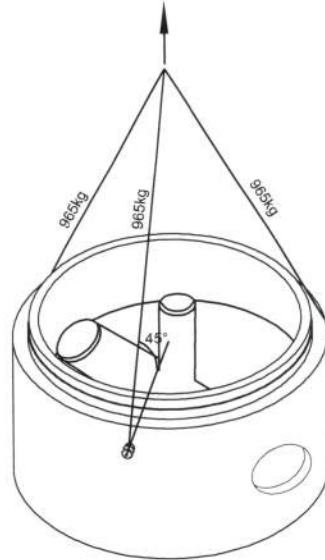

Lifting Detail

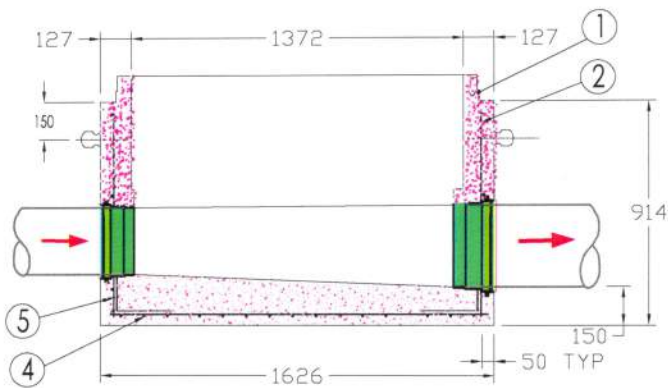
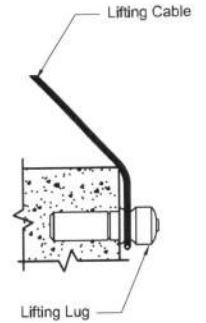

SECTION A-A
SCALE 1:30

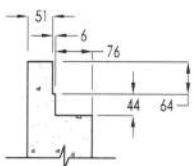

TONGUE & GROOVE DETAIL
SCALE 1:15

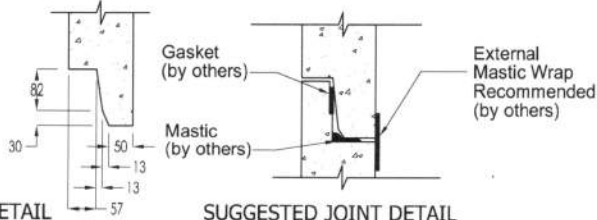

SUGGESTED JOINT DETAIL
SCALE 1:15

Specification and General Notes:

1. Manhole design/manufacture to ASTM C478M & CSA A257.3 Specification.
2. Concrete testing to ASTM C497/CSA 23.1 & 2-09.
3. Min. concrete compressive strength 30 MPa with Max. W/C ratio of 0.5
4. Gasket to ASTM C-443 specification (by others).
5. Concrete cover to be Min.25mm.
6. All dimensions to be millimeter.
7. Welded wire mesh overlap to be 300mm.
8. Manhole design and construction to MMCD manhole specification section 02725.
9. Manufacturing tolerance to be +/- 5mm.
10. Concrete Exposure Class to be A-3
11. Min. Stripping Strength to be 15MPa
12. All Form Finish to be Standard Grade
13. All Unformed Finish to be Steel Trowelled Finish or Wood Float Finish
14. Lifting cable and accessories to meet the strength requirement in lifting detail
15. Hoisting and Rigging system to meet WORK SAFE BC OHS Regulation Guideline Part 14/15



Description:	1372ID x 914H Prebenched Base
	54"ID x 36"H Prebenched Base 12043#
Project:	

Drawn :	Date :
D.N.	11/08/2014
Approved :	Load Rating:
V.W.	N/A
Rev. No. A	Scale :
	As Shown

Catalog No.	5436PB
Dwg. No.	54PB-1
Sheet No.	1 OF 1