

PLAN VIEW  
SCALE 1:20

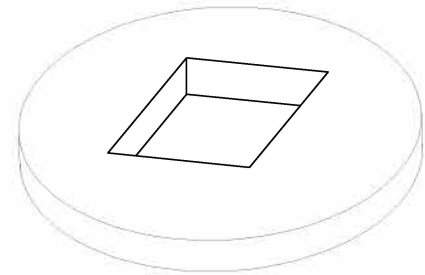

3D VIEW

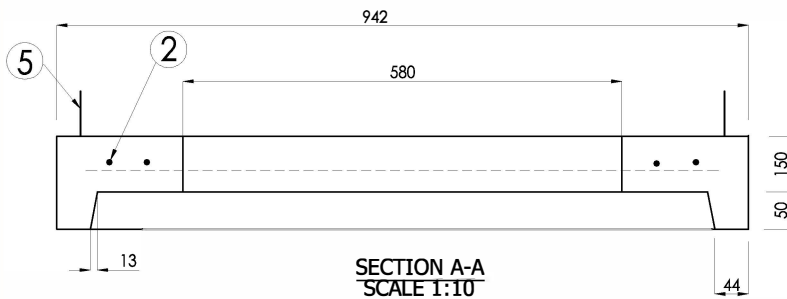

SECTION A-A  
SCALE 1:10

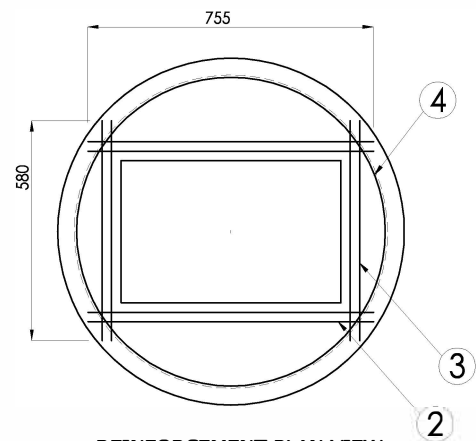

REINFORCEMENT PLAN VIEW  
SCALE 1:20

**Specification and General Notes:**

1. Manhole design/manufacture to ASTM C478M Specification.
2. Concrete testing to current version of ASTM C497/CSA 23.1 & 2.
3. Min. concrete compressive strength 30 MPa with Max. W/C ratio of 0.5.
4. Gasket to ASTM C-443 specification (by others).
5. Concrete cover to be Min.25mm.
6. All dimensions to be millimeter.
7. Welded wire mesh overlap to be 300mm.
8. Manhole design and construction to MMCD manhole specification section 02725.
9. Manufacturing tolerance to be +/- 5mm.
10. Concrete Exposure Class to be A-3.
11. Min. Stripping Strength to be 15MPa.
12. All Form Finish to be Standard Grade.
13. All Unformed Finish to be Steel Trowelled Finish or Wood Float Finish.
14. Lifting cable and accessories to meet the strength requirement in lifting detail.
15. Hoisting and Rigging system to meet WORK SAFE BC OHS Regulation Guideline Part 14/15



**Description:**  
**762 ID Donut Round Opening Female**

30"ID Donut Round Opening Female #340

**Project:**

Drawn : A.M	Date : 07/20/2015	<b>Catalog No.</b> <b>30DL-MOT</b>
Approved : V.W.	Load Rating: H20 RATED	<b>Dwg. No.</b> <b>30-13</b>
Rev. No. A	Scale : As Shown	<b>Sheet No.</b> 1 OF 1