

Custom Poured Extended Base

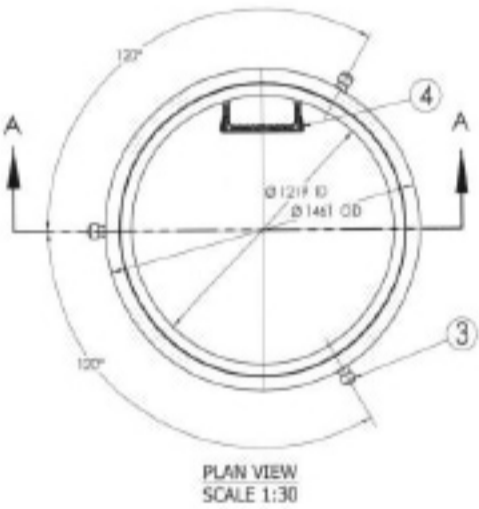
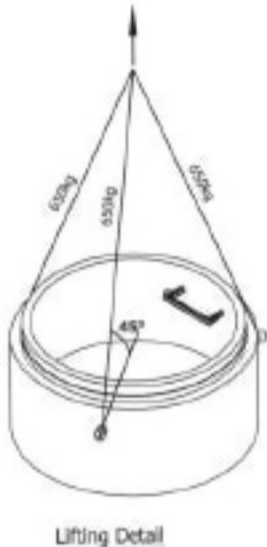

4824B

Specification and General Notes:

- Manhole design manufactured to ASTM C478 & CSA A23.4 Specification.
- Concrete casting to ASTM C478 / CSA A23.4 2.1.1.
- 5% concrete compressive strength: 32 MPa with min. 14% rate of 0.5.
- Joint to ASTM C-478 (Specification for Joints).
- Concrete cover to be min. 25mm.
- 50 MPa strength to be minimum.
- Product will meet strength to be 3000psi.
- Manhole design and construction to MMCD manhole specification section 0210.
- Manufacturing tolerance to be +/- 20mm.
- Concrete Engineering Code 1010-A.1.1.
- All lifting equipment to be 150kN.
- All forms to be Standard Grade.
- All surface finish to be Smooth Trowelled Finish or Smooth Floor Finish.
- Lifting cable and accessories to meet strength requirement in Appendix.
- Hoisting and rigging system to meet CSA S109 - RC CMA Reg. Code (Canadian Part 1415).

DIAMOND PRECAST CONCRETE	Description	1219ID x 610H Manhole Base TT LR2	Drawn: P.J.V.	Date: 06/16/2004	Catalog No. 4824B
		48"ID x 24"H Manhole Base TT LR2 3200 #	Approved: J.S.A.	Used Rating: 704	Prog. No. 48-02
7520 Central Street Burnaby, B.C. V5A 2H7 Phone: 604-415-5181 Fax: 604-415-5285 www.diamondconcrete.ca		Project:	Rev. No:	Scale: As Shown	Sheet No. 1 OF 1



COMPLETE CAPABILITIES



COMPLETE CAPABILITIES



WEBSITE

diamondprecast.com



OPT-IN

Weekly Newsletters